

# Safety windows for vehicles and construction machinery



 Strigin®

# Table of Contents

- 1 Introduction
- 2 Certification
- 3 Frame construction and finishing
- 4 Glass
- 5 Installation

# 1 Introduction

## **Strigin Automotive**

Strigin's safety solutions for vehicles, construction machinery and mining machinery are designed and manufactured in accordance with SveMin's "Instructions for vehicles, machinery and technical equipment."

SveMin's working environment and safety instructions apply to vehicles and machinery in the mineral and mining industry. SveMin is the owner of the instructions, and GRAMKO (the Mining and Mineral Industries Working Environment Committee) is responsible for their development and administration.

In order to meet the requirements for personal safety in the industry, Strigin's products have been tested and certified in accordance with current European standards EN 1063 and EN13123 and often meet higher requirements than specified.

To ensure total control over the quality and manufacturing process, all development, design and manufacture is under our own control.

We also offer complete solutions that, in addition to safer windows, reduce noise, eliminate condensation and frost, reduce solar heat radiation and more.

## **Excerpt from "SveMin's Instructions for Vehicles, Machinery & Technical Equipment"**

### **1.9 Cab**

#### **1.9.1 ROPS, FOPS and OPS**

*Cabs should be designed with protective structures that at the very least meet the requirements of a harmonized standard, both to reduce the risk to the driver of the machinery overturning or rolling onto its roof (ROPS, SS-EN ISO 3471) and to protect the driver against falling objects (FOPS, SS-EN ISO 3449) or prevent objects from entering the operator's cab (OPS, the standard SS-ISO 8084 for forest machines, lays down indicative requirements for operator protection).*

*Protection from projectiles (so-called blast protection) is a requirement for mining machinery such as loaders, scrapers, drilling units, boulder handling equipment, etc.*

*Safety glass should withstand explosions and projectiles. For all windwindows at risk of projectiles, safety glass is recommended that at least meets the requirements corresponding to SS-EN 1063 class BR4 or SS-EN 15152 section 6.2.6 with  $v_p = 450$  km/hr.*

*All other windows must be shatter proof.*

*Vehicles equipped with a roof hatch or skylight must be supplemented with protection giving the same load-bearing capacity as vehicles without a roof hatch or skylight.*

*On articulated machinery, steering must be deactivated when the machine is stationary and the door is open.*

## 2 Certification

- Tested and certified bulletproof, level BR4NS as per SS-EN 1063.  
*Protection against explosives, chain shot and projectiles.*
- Tested and certified safe against explosions, level EXR3 as per SS-EN 13124-2: 2004 and SS-EN 13123-2:2004.  
*Protection against shock wave and pulse in case of unexpected detonation.*
- Tested and certified, manual attack level P8B as per SS-EN 356.  
*Protection against attack and stress from sharp and blunt objects.*

All tests, samples and approvals of Strigin Säkerhetsglas AB's products are carried out by accredited bodies to ensure compliance with applicable rules, standards and laws.

Strigin Säkerhetsglas AB cooperates, amongst others, with RISE (formerly SP) for testing and certification.



### 3 Frame construction and finishing

The frame of our safety windows is a unique product with a design developed and manufactured by Strigin Säkerhetsglas.

The basic design is always the same but is adapted to the current vehicle to ensure field of vision, fit and sealing.

Manufacture, from unprocessed steel to finished lacquered frame, is carried out in our own premises by our own personnel to ensure full control over the manufacturing process and quality.

Strigin manufactures the frames in structural steel with licensed welding technology.

Screws, bolts and nuts are zinc-nickel anodised for optimum life-span and corrosion protection.

The frame is powder coated, primer and topcoat, and comes with a five-year "Florida warranty".

Our frame construction is designed to enable easy installation in the minimum time, which means that installation can also be carried out in the field (if required). Construction and design is patent pending.

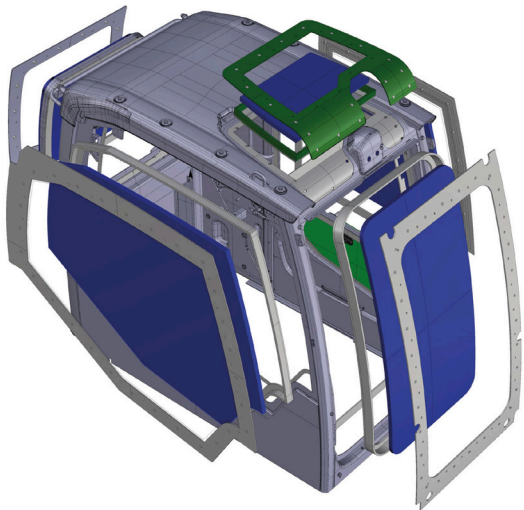

## 4 Glass

The glass used in our safety windows is the most important part of the finished product.

**Glass as a material has several unique properties:**

- It is ageing resistant, which means it does not turn yellow or change its appearance over time.
- It has very good properties in terms of wear, scratch resistance and strength. This is important as our products are most often used in "aggressive environments" with a lot of dust and dirt.
- It has exceptionally good optical properties compared to other materials.

**Strigin safety glass is:**

- Made of 22 mm laminated safety glass.
- Tested and certified BR4NS as per SS-EN 106.
- Tested and certified EXR3 as per SS-EN 13124-2:2004 and SS-EN 13123-2:2004.

Glass properly manufactured and assembled is a material which is hard to beat, and that is why Strigin Säkerhetsglas has chosen to use glass alone in our safety windows.

Strigin only works with the highest quality glass.

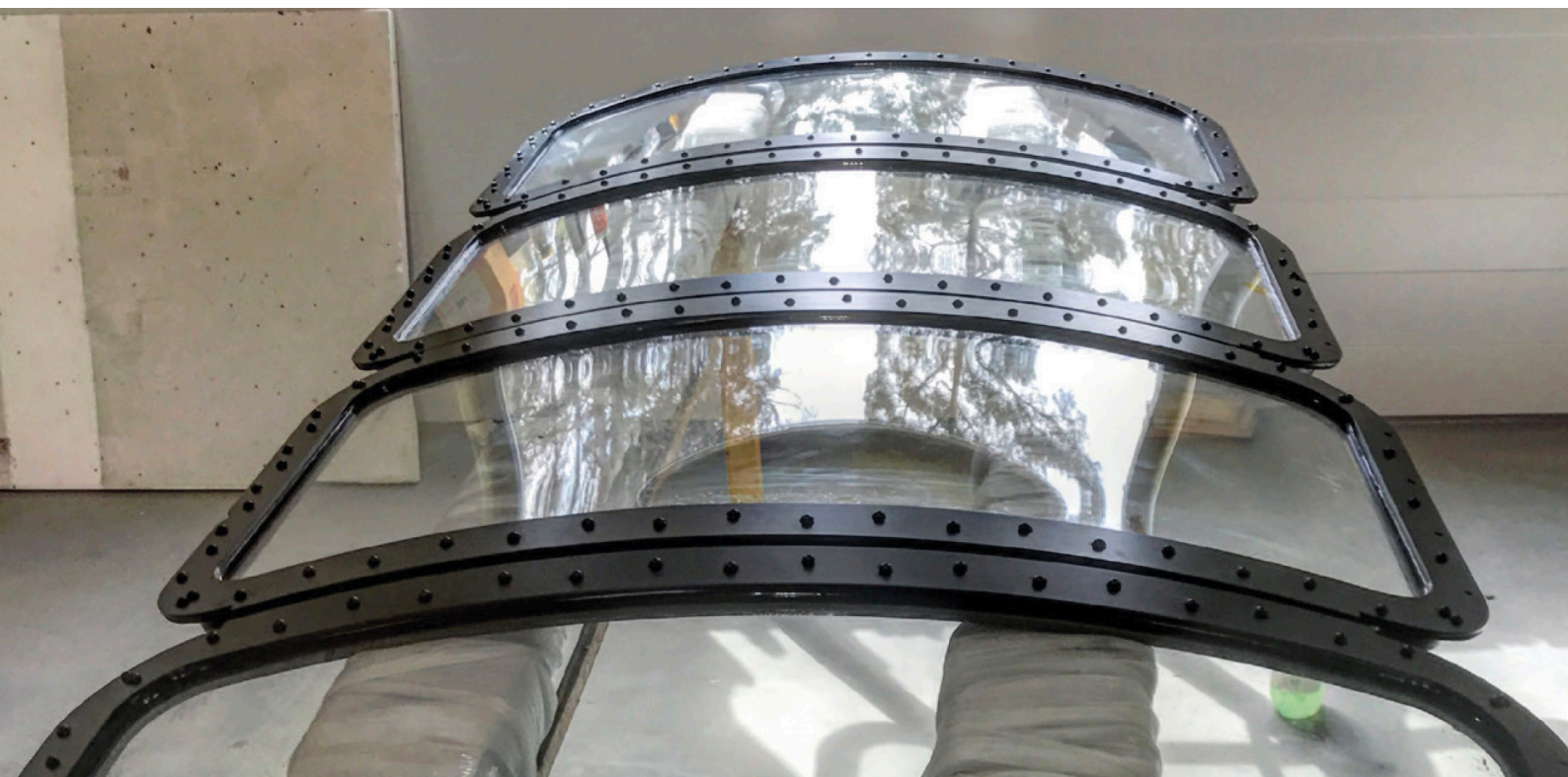

## 5 Installation

Strigin safety windows are manufactured to make them easy to install, including with regard to size and weight. Comprehensive installation instructions are included with all deliveries and show the different steps. We are available by phone and mail for any queries.

We offer training for installation staff and we can of course assist with installation if desired.

- All deliveries include the installation instructions.
- Simple installation that can also be carried out in the field.
- No need for sealants or the like.
- The frame structure is adapted to the greatest extent possible to enable the reinstallation of original parts such as windscreen wipers, roller blinds, suncaps, etc.
- No drying times or downtime, the vehicle can be used immediately after installation.



[strigin.se](https://strigin.se)

